

GULL WING CRYO-QUICK™ CRYOGENIC FREEZER

HIGH PERFORMANCE WITH TOTAL CONVEYOR ACCESS



FLEXIBLE PRODUCTION CAPACITIES

The **GULL WING CRYO-QUICK™** freezer has throughput capacities ranging from 100 kg per hour to 300 kg per hour or more in a standard range of machines. It can and does handle virtually any type of food - fish, meat, poultry, vegetables, fruit, confectionery and bakery products. The **CRYO-QUICK™** freezer is basically a conveyor encased in an efficient insulated tunnel. Food is carried along the conveyor and under spray headers which are connected to a controlled liquid nitrogen supply.

BETTER FOOD TEXTURE AND TASTE

Liquid nitrogen has a temperature of -196°C . When vaporised in contact with the food it absorbs heat very fast. The ultra low temperature and high heat transfer rate leads to rapid freezing.

This minimises large ice crystal formation and helps preserve food texture. It also cuts drip loss and dehydration to almost nothing, leaving the product with a better colour, better texture and better taste. The expendable refrigerant gas is controlled and directed down the tunnel to efficiently precool the incoming food. The high velocity circulating fans create extremely rapid cooling of food in the gas sections of the freezer. This increases the heat transfer from the food and leads to highly efficient nitrogen use.

EASILY EXPANDED

Whilst offering a low capital cost alternative to traditional methods of food freezing, one of the most important benefits of the **CRYO-QUICK** is its compatibility - the ease with which it can be fitted into existing production systems. It comes in a range of widths to accommodate most

upstream and downstream processing equipment. The **CRYO-QUICK** can also be installed alone or in conjunction with a Cryo-Dip immersion freezer to give premium IQF products. The freezer is built in modules so that it can be easily expanded. Stepping up production on to the **CRYO-QUICK** is a simple matter; you just increase the nitrogen flow and speed up the conveyor. In this way the nominal capacity can be increased by as much as 30%.

The **CRYO-QUICK** fits naturally with flow-line production and with an automated control system it requires minimum attention. As the only major moving parts are the fans and the conveyor, maintenance is reduced to a minimum. The pneumatically operated gull wings provide easy access for cleaning. The total simplicity means minimum down-time, maximum flexibility and a perfect frozen product.

NOTES

- Max product height = 125mm
- Infeed and outfeed height = 950mm ± 50mm
- Usable surface area = B x D
- Tunnel to be installed with 0.5° slope down to feed table
- Control panel can be mounted on left or right side or can be free standing
- 660 models are fitted with 1°N scroll fan, 915 and 1220 models have two.

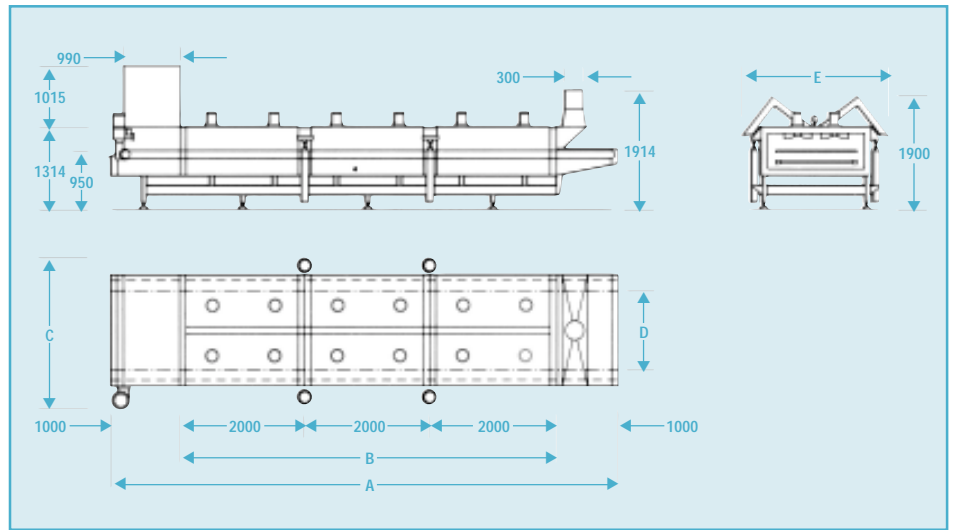

Dimensions Model number	Overall length Am	Usable length Bm	Overall width closed Em	Usable width Dm	Overall width open Em	axial fan motors	3 phase electric supply kW total	Approx weight kg
GW660.6			1.712	0.660	1.782	5	10	2300
GW915.6	8.1	6.0	2.016	0.915	2.086	10	15	2650
GW1220.6			2.332	1.220	2.390	10	15	3150
GW660.8			1.712	0.660	1.782	7	12	2850
GW915.8	10.1	8.0	2.016	0.915	2.086	14	19	3250
GW1220.8			2.332	1.220	2.390	9	13	3400
GW660.10			1.712	0.660	1.782	7	12	2850
GW915.10	12.1	10.0	2.016	0.915	2.086	18	21	4050
GW1220.10			2.332	1.220	2.390	18	21	4750
GW660.12			1.712	0.660	1.782	11	15	4050
GW915.12	14.1	12.0	2.016	0.915	2.086	22	24	4600
GW1220.12			2.332	1.220	2.390	22	24	5500
GW660.14			1.712	0.660	1.782	13	16	4490
GW915.14	16.1	14.0	2.016	0.915	2.086	26	27	5250
GW1220.14			2.332	1.220	2.390	26	27	6150
GW660.16			1.712	0.660	1.782	15	18	5250
GW915.16	18.1	16.0	2.016	0.915	2.086	30	30	5950
GW1220.16			2.332	1.220	2.390	30	30	7050
GW660.18			1.712	0.660	1.782	17	19	5550
GW915.18	20.1	18.0	2.016	0.915	2.086	34	33	6300
GW1220.18			2.332	1.220	2.390	34	33	7800
GW660.20			1.712	0.660	1.782	19	21	5950
GW915.20	22.1	20.0	2.016	0.915	2.086	38	36	7350
GW1220.20			2.332	1.220	2.390	38	36	8300

© Air Products and Chemicals, Inc. - 2000 - TILT - 05/00 - 5000UK-MC2094

Food Industry Group

Air Products PLC
 2 Millennium Gate
 Westmere Drive
 Crewe CW1 6JA
 Tel: (0800) 441270
 Fax: (1270) 506517
www.airproducts.com/food